



The WSP is Exclusively
Distributed by EPG Pumps
1800 351 755
www.weirselfprimer.com.au



Patent Pending

Pump Size	4"x4" • 100 mm x100 mm ANSI/DIN
Pump Casing	Ductile Iron
Operating Pressure	Maximum 120 psi (797 kPa)
Impeller	Open type, two vane. Material - Cast Steel Pumps 3" (76.2 mm) solids
Impeller Shaft	17-4PH SST
Wear Plate, Replaceable	Hardened steel
Cover Plate	Removable/Adjustable Ductile Iron 30
Flap Valve	Neoprene with steel reinforcing ring
Bearing Housing	Ductile Iron
Seal Plate	Ductile Iron
Shaft Sleeve	17-4PH SST
Radial Bearing	Open single ball
Thrust Bearing	Open double ball
Bearing/Seal Cavity Lubrication	SAE No. 20 oil
Flanges	125# Ductile Iron ANSI or DIN
Gaskets	Buna-N, compressed synthetic fibers, vegetable fiber, PTFE, cork, and rubber
O-Rings	Buna-N - Teflon coated
Hardware	Plated steel/Grade 8/SST
Pressure Release Valve	Brass
Oil Level Sight Gauges	Bearing and Seal Cavity

Optional Equipment and Materials

Hi-Chrome, CD4MCU. Automatic air release valve, 120V/240V casing heater. High pump temperature shutdown kit, moisture probe, gauge kit, NPT & DIN standard suction and discharge flanges. Other elastomers available.

Seal Specifications

Mechanical oil-lubricated, double floating, self-aligning seal. Silicon Carbide rotation and stationary faces. Stainless steel metal components. Maximum temperature of liquid pumped 180°F/83°C.

Note: Consult factory for applications exceeding maximum pressure and/or temperature indicated.

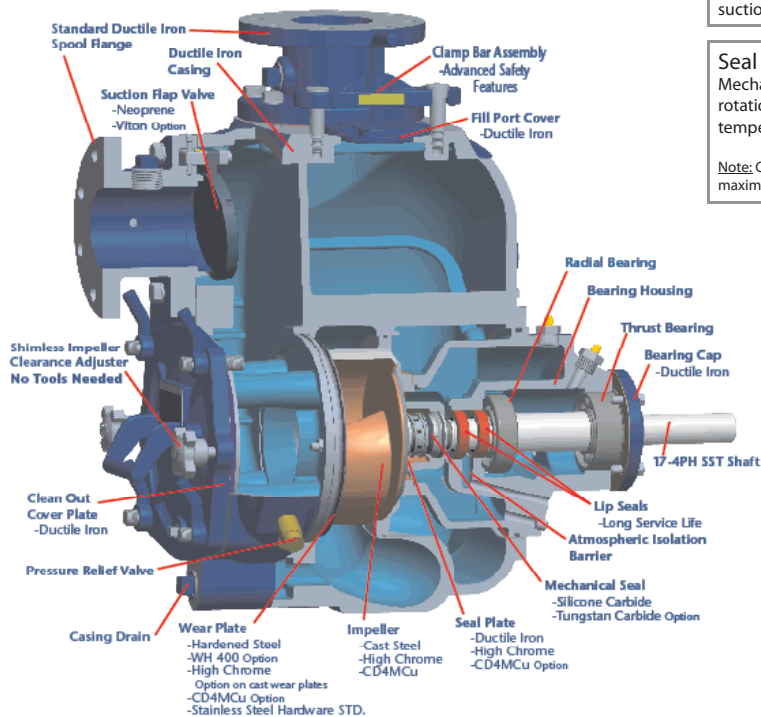

Seal Detail View

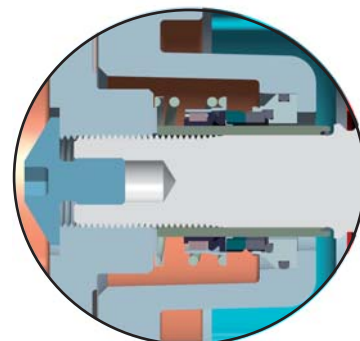



Pump Size	4"x4"/100 mm x100 mm
Net Weight	625 lbs./260 KG.
Shipping Weight	675 lbs./300 KG
Export Crate	25 Ft ³ / 0.7 M ³

